



Product Specification For TFT MODULE

Model NO. : CNKT0700-21375A1

CUSTOMER NO. :

REVISION : V00

□ APPROVAL FOR SPECIFICATIONS AND SAMPLE

CUSTOMER APPROVAL	APPROVED BY	DATE

CNK R&D CENTER		
APPROVED BY	REVIEWED BY	PREPARED BY
		



地址：福建省龙岩市武平县武平工业园区工业大道 11 号二号厂房

电话：0597-3058111

传真：0597-3058555

<http://www.szcnk.com>

CONTENTS

1.	Display Characteristics	3
2.	Pin Assignments	3
3.	Absolute Maximum Ratings	4
4.	Electrical Characteristics	4
5.	Backlight Characteristics	4
6.	Optical Specifications	5
7.	AC Characteristics	7
8.	Power sequence	7
9.	Reliability Test Conditions	7
10.	Handling Precautions	7
11.	Inspection Criterion	8
12.	Mechanical Drawing	16

Version	Date	Description
V00	2021/12/29	First released

1. Display Characteristics

Item	Specification	Unit	Note
LCD Size	7.0	inch	
Panel Type	IPS	-	
Resolution	280(RGB)(H)x1424(V)	pixel	
Display Mode	TRANSMISSIVE,NORMALLY BLACK	-	
Display Number of Colors	262K	-	
Viewing Direction	ALL VIEWING	-	Note1
Module Size	181.47*38.2*3.4	mm	Note1
Weight	TBD	g	
Driver IC	OTA7290B	-	
Interface	MIPI	-	

Note 1: Please refer to the mechanical drawing.

2. Pin Assignments

Pin No.	Symbol	Function	Note
1	VCOM	Common Voltage(3.7~6.86V, Typ:5.28V).	
2	VDD	Power Supply.	
3	VDD	Power Supply.	
4	NC	-	
5	RESET	Global reset pin	
6	STBYB	Standby mode. Normally pull high.	
7	GND	Power Ground	
8	D0-	MIPI data input	
9	D0+	MIPI data input	
10	GND	Power Ground	
11	D1-	MIPI data input	
12	D1+	MIPI data input	
13	GND	Power Ground	
14	D2-	MIPI data input	
15	D2+	MIPI data input	
16	GND	Power Ground	
17	CLK-	Clock input	
18	CLK+	Clock input	
19	GND	Power Ground	
20	D3-	MIPI data input	
21	D3+	MIPI data input	
22	GND	Power Ground	
23	NC	-	
24	NC	-	

25	GND	Power Ground	
26	NC	-	
27	NC	-	
28	NC	-	
29	AVDD	Power supply for analog circuits(11.38V).	
30	GND	Power Ground	
31	LEDK	backlight K-	
32	LEDK	backlight K-	
33	L/R	Source Right or Left sequence control.	
34	U/D	Source Up or Down sequence control.	
35	VGL	VGL voltage for GIP control circuit(-10.27V).	
36	NC	--	
37	NC	--	
38	VGH	VGL voltage for GIP control circui(15.37V).	
39	LEDA	Power for LED backlight (Anode)	
40	LEDA	Power for LED backlight (Anode)	

3. Absolute Maximum Ratings

Item	Symbol	Min	Max	Unit
Power supply	VDD	-	5.5	V
Operation temperature	Top	-20	70	°C
Storage temperature	Tst	-30	80	°C

4. Electrical Characteristics

DC CHARACTERISTICS (at Ta=25°C)

Item	Symbol	Values			Unit	Note
		Min.	Typ.	Max.		
Logic Supply Voltage	VDD	2.7	3.3	3.6	Vdc	
Supply Voltage For Panel	VGH	-	15.37	-	V	
	VGL	-	-10.27	-		
Input Logic High Voltage	VIH	0.8VDD	-	VDD	V	
Input Logic Low Voltage	VIL	0	-	0.2VDD	V	
Output Logic High Voltage	VOH	VDD-0.4	-	--	V	
Output Logic Low Voltage	VOL	GND	-	GND+0.4	V	

5. Backlight Characteristics

(at Ta=25°C,RH=60%)

Item	Symbol	Min.	Typ.	Max.	Unit	Note
LED forward voltage	VF	21.0	24.0	27.0	V	IF=1*20mA
LED forward current	IF	--	20	--	mA	
LED power consumption	PLED	--	-	--	mW	Note1
Uniformity	--	75	80	---	%	IF=20mA
Connection mode	--	8 series			/	
LED life-time	--	20000	--	--	Hrs	Note2

Note1. Calculator Value for reference: $IF \cdot VF = PLED$

Note2. The LED Life-time define as the estimated time to 50% degradation of initial brightness at Ta=25°C and IF=180mA. The LED lifetime could be decreased if operating IF is larger than 180mA

6. Optical Specifications

Item	Symbol	Condition	Min	Typ	Max	Unit	Note
Response time	Ton+ Toff	Normal $\theta = \Phi = 0^\circ$	-	30	40	ms	Note 4,5
Contrast ratio	Cr		--	800	-	-	Note 1.5
Surface luminance	Lv	$\theta = 0^\circ$	TBD	TBD	-	cd/m ²	Note 2,5
Viewing angle range	θL	Left(CR>10)	-	80	-	deg	Note 5,6
	θR	Right(CR>10)	-	80	-	deg	
	θT	Top(CR>10)	-	80	-	deg	
	θB	Bottom(CR>10)	-	80	-	deg	
CIE (x, y) chromaticity	Red x	$\theta = 0^\circ$ $\Phi = 0^\circ$ Ta=25°C	Typ -0.03	0.644	Typ +0.03	-	Note 3,5
	Red y			0.332		-	
	Green x			0.324		-	
	Green y			0.566		-	
	Blue x			0.137		-	
	Blue y			0.125		-	
	White x			0.319		-	
	White y			0.343		-	

Note1. Definition of contrast ratio

Contrast Ratio(CR) is defined mathematically by the following formula.

$$\text{Contrast Ratio} = \frac{\text{Average Surface Luminance with all white pixels}}{\text{Average Surface Luminance with all black pixels}}$$

Note 2. Definition of surface luminance

Surface luminance is the LCD surface from the surface with all pixels displaying white.

Lv = Average Surface Luminance with all white pixels

Note 3. Definition of color chromaticity (CIE1931)

CIE (x, y) chromaticity , The x,y value is determined by screen active area center position

Note 4: Definition of response time

The response time is defined as the LCD optical switching time interval between “White” state and “Black” state. Rise time (T_{on}) is the time between photo detector output intensity changed from 90% to 10%, and fall time (T_{off}) is the time between photo detector output intensity changed from 10% to 90%.

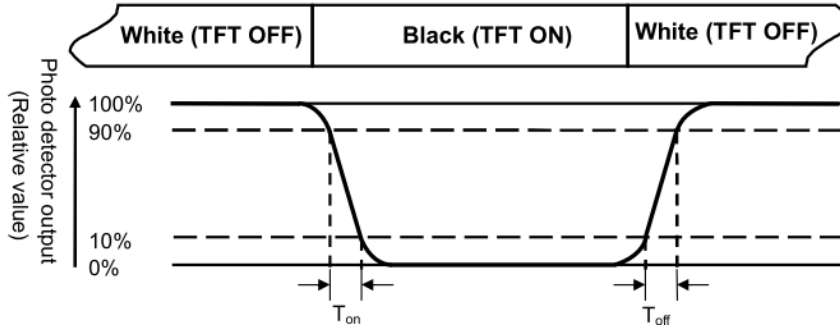

Note 5: Definition of viewing angle

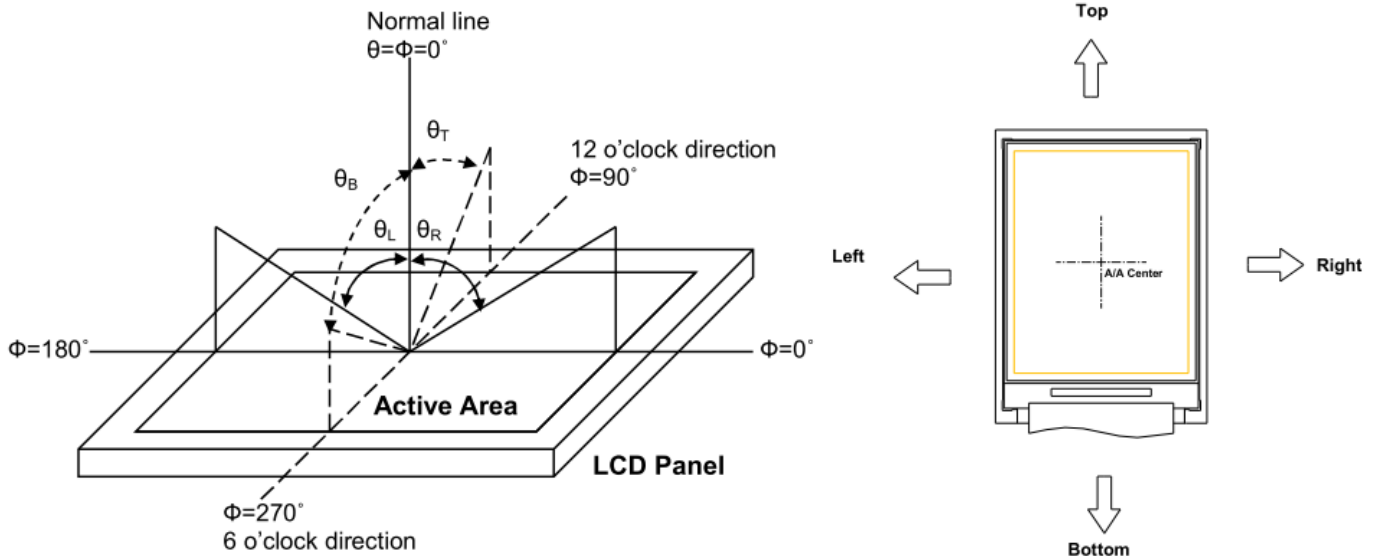

Note 6: Definition of optical measurement system

The optical characteristics should be measured in a dark room with ambient temperature $T_a = +25$. The optical properties are measured at the center point of the LCD screen after 5 minutes operation. (Equipment: Photo detector TOPCON BM-5A or BM-7 /Field of view: 1° /Height: 500mm.)

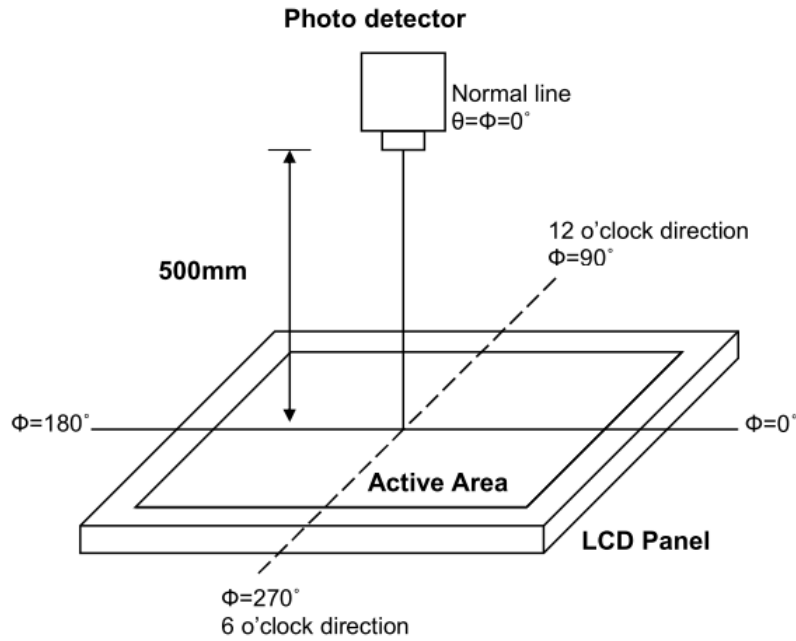

7. AC Characteristics

Refer to IC datasheet

8. Power sequence

Refer to IC datasheet

9. Reliability Test Conditions

Test item	Test condition	Inspection after test
High temperature storage	80±2°C/240 hours	Note 1,2
Low temperature storage	-30±2°C/240 hours	
High temperature operating	60±2°C/24hours	
Low temperature operating	-20±2°C/24 hours	
Temperature Shock	-20±2°C~25°C~70±2°C*10cycles (30min.) (5min.) (30min.)	
High Temperature Humidity Operation	60°C*90% RH/96 hours	
Vibration test	Frequency : 10Hz~55Hz~10Hz Amplitude : 1.5mm , X , Y , Z direction for total 2hours(Packing condition)	
Dropping test	Drop to the ground from 1m height, one time, every side of carton. (Packing condition)	

ESD test	Voltage : $\pm 8\text{KV}$, R:330 Ω /C:150pF Air discharge, 10 time	
----------	--	--

10. Handling Precautions

10.1. Safety

10.1.1. The liquid crystal in the LCD is poisonous. do not put it in your mouth. If the liquid crystal touches your skin or clothes, wash it off immediately using soap and water.

10.2. Handling

10.2.1. The LCD and touch panel is made of plate glass. do not subject the panel to mechanical shock or to excessive force on its surface.

10.2.2. do not handle the product by holding the flexible pattern portion in order to assure the reliability

10.2.3. Transparency is an important factor for the touch panel. Please wear clear finger sacks, gloves and mask to protect the touch panel from finger print or stain and also hold the portion outside the view area when handling the touch panel.

10.2.4. Provide a space so that the panel does not come into contact with other components.

10.2.5. To protect the product from external force, put a covering lens (acrylic board or similar board) and keep an appropriate gap between them.

10.2.6. Transparent electrodes may be disconnected if the panel is used under environmental conditions where dew condensation occurs.

10.2.7. Property of semiconductor devices may be affected when they are exposed to light, possibly resulting in IC malfunctions.

10.2.8. To prevent such IC malfunctions, your design and mounting layout shall be done in the way that the IC is not exposed to light in actual use.

10.3. Static Electricity

10.3.1. Ground soldering iron tips, tools and testers when they are in operation.

10.3.2. Ground your body when handling the products.

10.3.3. Power on the LCD module before applying the voltage to the input terminals.

10.3.4. do not apply voltage which exceeds the absolute maximum rating.

10.3.5. Store the products in an anti-electrostatic bag or container.

10.4. Storage

10.4.1. Store the products in a dark place at $+25^{\circ}\text{C} \pm 5^{\circ}\text{C}$ with low humidity (65%RH or less).

10.4.2. do not store the products in an atmosphere containing organic solvents or corrosive gas.

10.5. Cleaning

10.5.1. do not wipe the touch panel with dry cloth, as it may cause scratch.

10.5.2. Wipe off the stain on the product by using soft cloth moistened with ethanol. do not allow ethanol to get in between the upper film and the bottom glass. It may cause peeling issue or defective operation. do not use any organic solvent or detergent other than ethanol.

11. Inspection Criterion

1.1 Description

This specification is made to be used as the standard acceptance/rejection criteria for TFT LCM Product.

11.1.1. Sample plan

Sampling plan according to GB/T2828.1-2003/ISO 2859-1 : 1999 and ANSI/ASQC Z1.4-1993, normal level 2 and based on:

Major defect: AQL 0.65

Minor defect: AQL 1.5

11.1.2. Inspection condition

● Viewing distance for cosmetic inspection is about 30 ± 5 cm with bare eyes, and under an environment 600~1000lux for visual inspection and 0~200lux for function test., all directions for inspecting the sample should be within 45° against perpendicular line. (Normal temperature $18 \sim 28^\circ\text{C}$ and normal humidity $60 \pm 15\% \text{RH}$).

● Driving voltage

The Vop value from which the most optical contrast can be obtained near the specified Vop in the specification (Within $\pm 0.5\text{V}$ of the typical value at 25°C .)

11.1.3. Definition of inspection zone in LCD

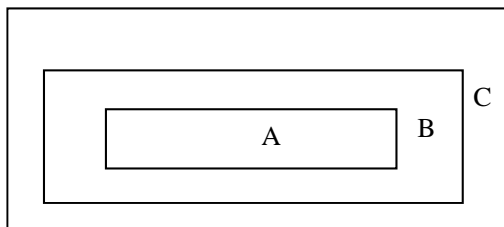

Zone A: character/Digit area

Zone B: viewing area except Zone A (Zone A+Zone B=minimum Viewing area)

Zone C: Outside viewing area (invisible area after assembly in customer's product)

Fig.1 Inspection zones in an LCD.

Note: As a general rule, visual defects in Zone C are permissible, when it is no trouble for quality and assembly of customer's product.

11.2 Inspection criterion

11.2.1 Function defect

Items to be inspected	Inspection criterion	Classification of defects
-----------------------	----------------------	---------------------------

All functional defects	1) No display 2) Display abnormally 3) Missing vertical , horizontal segment 4) Short circuit 5) Back-light no lighting, flickering and abnormal lighting. 6) obvious striation 7) Current beyond specification value	MA
Missing	Missing component	
Outline dimension	Overall outline dimension exceed the drawing is not allowed.	

11.2.2 LCD pixel defect (bad dot) (defect type:MI)

Checking item Item/LCD size	Judgment criterion		
	S ≤5.0 Inch	5.0 < S≤7.0 Inch	7 < S≤12.3 Inch
Color bad dot-bright dot(R、 G、 B)	1	2	3
two adjacent bright point	0	1	2
three or more adjacent point	0	0	0
total points for bad dot-bright dot	1	2	5
Bad dot-dark dot	2	4	5
two adjacent dark point	1	2	3
three or more adjacent point	0	1	1
total points for bad dot -dark dot	3	6	7
patch bright dot	Invisible with ND5%,it is OK.		

11.2.3 dot and line defect (defect type:MI)

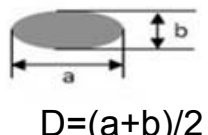
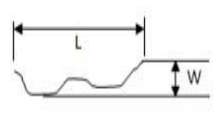
Checking item	Judgment criterion				Figure	
	Diameter(mm)\LCD Size	S ≤5.0 Inch	5 < S≤7 Inch	7 < S≤12.3 Inch		
Dot defect	D≤0.1	allowed	allowed	allowed	 $D=(a+b)/2$	
	0.1 < D≤0.2	4	allowed	allowed		
	0.2 < D≤0.3	0	5	6		
	0.3 < D≤0.5	0	0			
	D > 0.5	0	0	0		
	the distance between the two defect dot:DS≥5mm					
line defect	Length(mm)	width(mm)	Judgment criterion			
	disregard	W≤0.05	allowed	allowed	allowed	
	L≤5	0.05 < W≤0.1	4	5	7	
	L > 5	W > 0.1	0	0	0	

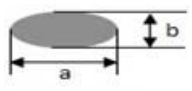
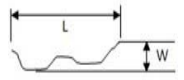
Concave point and air bubble for polarizer	LCD Size(mm)		Judgment criterion			 $D=(a+b)/2$
	D≤0.3		allowed	allowed	allowed	
	0.3 < D≤1.0		3	4	5	
	1.0 < D≤1.5		1	2	3	
	D > 1.5		0	0	0	
Fold mark, linear scar for polarizer	Length (mm)	width (mm)	Judgment criterion			
	disregard	W≤0.05	allowed	allowed	allowed	
	1 < L≤5	0.05 < W≤0.2	3	4	5	
	L > 5	W > 0.2	0	0	0	
Notes:1.If the fold mark and linear scar for polarizer is visible with operating condition,the defect is judged with line judge ; 2.If the fold mark and linear scar for polarizer is visible with non-operating condition,the defect is judged with the above judgment standard.						

11.2.4 Corner and others crack for LCD (defect type:MI)

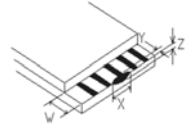
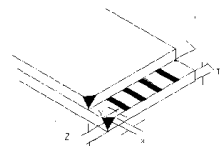
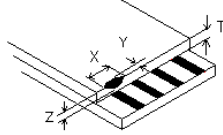
Checking item	Judgment criterion	Figure
Electric conduction crack	$X \leq 3.0\text{mm}, Y \leq 1/4w, Z \leq t, N \leq 2$	
corner crack	$X \leq 3.0\text{mm}, Y \leq 3.0\text{mm}, Z \leq t, N \leq 3$ Corner crack extended to ITO PIN, none allowed	
surface crack	$X \leq 1.5\text{mm}, Y \leq 1.0\text{mm}, Z \leq t, N \leq 4$	

11.2.5 Module Cosmetic Criteria (defect type:MI)



Item	Judgment Criterion
Difference in Spec.	None allowed
Pattern peeling	No substrate pattern peeling and floating
Soldering defects	No soldering missing No soldering bridge No cold soldering

	Notes:detail judgment referring to IPC-A-610 grade II
Resist flaw on Printed Circuit Boards	visible copper foil (0.5mm or more) on substrate pattern, none allowed
Accretion of metallic Foreign matter	No accretion of metallic foreign matters (Not exceed 0.2mm)
Stain	No stain to spoil cosmetic badly
Plate discoloring	No plate fading, rusting and discoloring
Newton ring	Referring to limited sample
Mura	Invisible with 5%ND,allowed
Light leaks	Referring to limited sample

11.2.6 Module Cosmetic Criteria

Inspection items	Inspection content	Defect level		Inspection Methods and Tools
		MAJ	MIN	
FPC segment	The PIN cannot be broken.	√		Inspection with naked eyes Standard card Magnifier
	Fold marks: Not in V" shape	√		
	Pin/line: concave, convex, skewed not to exceed 1/3 of width		√	
	Double-sided adhesive tape cannot fall off/skew		√	
	Oxidation on pins (PAD) is not allowed		√	
	open circuit /short circuit is not allowed on line	√		
	Line / line: non-conductive sundries must not cross two lines, conductive sundries according to convex / concave judgment		√	
	The PAD on the product do not warp, deform or fall off		√	
	Scratch: Scratch is not allowed on the film		√	
	Cover film: the sticker offset must not exceed the drawing requirements		√	
	Bubbles: Bubbles must not span 2 lines and must not exceed 2		√	
	Stratification: product is not layered	√		
Screen printing: screen printing should be clear, not duplicate, missing or wrong		√		
Back-light	Guide pin indispensable/unbroken		√	
	No surface breakage/crack	√		
	Reflex tape/ FPC not dropped		√	

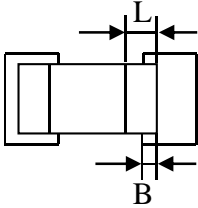
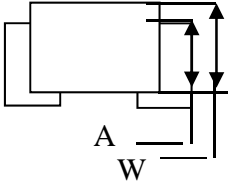
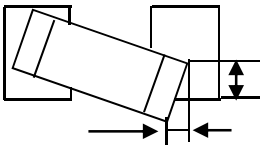
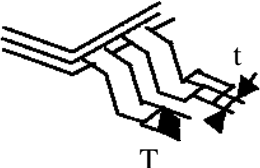
	The double-sided glue on the light guide plate must not be removed		√	
SMT segment	Solder not melted	√		
	Component standing or solder joint and end face disengage	√		
	Tin beads: removable tin beads not available, non-removable tin beads not exceeding 0.2 MM in diameter		√	
SMT segment	Line 1. Broken circuit or short circuit not allowed 2. Line damage or residual copper no more than 1/3 W	√		Visual Standard card Magnifier
	Scratch on the surface 1. scratch copper, reject 2. copper single line (not covered with green paint)>1 mm, reject 3. No more than 2 lines and exposed copper		√	
	Part error 1. Part specification, material number failed to match original part data ,reject 2. missing /multiple parts: no missing or multiple parts on the circuit board 3. reverse: no positive and negative wrong welding of parts on circuit board	√		
	Tin on board 1. Tin in front of 1/2 Lead, reject 2. products have hot pressing process, its gold finger (pressing area) tin, reject		√	
	Empty welding: welding surface and pad are not joint	√		
	No tin tip / crack or virtual welding		√	
	No white powder residue		√	

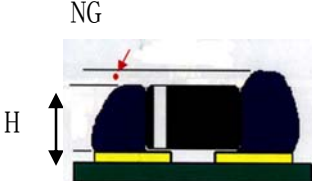
	<p>Component offset</p> <p>1. $B \geq 1/2 \geq L$</p>  <p>2. $A \geq 2/3 \bullet W$</p>  <p>3. $A \geq 2/3 \bullet W$ $B \geq 1/2 \bullet L$</p>  <p>4. $t \geq 1/2 \bullet T$</p>  <p>Reference 1,2</p>		√	
SMT segment	<p>Solder height is higher than solder foot 1.25 H(gull airfoil), reject</p>  <p>Solder height is higher than surface (round type), reject</p> 		√	Visual Standard card Magnifier

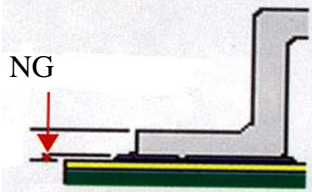
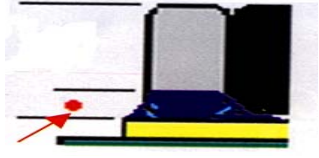
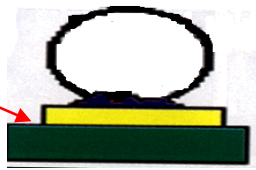
	<p>Gull airfoil: Solder height less than solder foot $1/3 H$, or the solder pad less than 70% tin, reject</p>  <p>Cylindrical type: solder height less than surface $1/4 H$ or the solder pad less than 70% tin, reject</p>  	√		
	Connectors (including: card cover) are not broken or dropped	√		
	Board warping: the gap between the PCB and the plane is not greater than $1/100$ of the length (if no special requirements, according to this standard)		√	
Other	SI/UV adhesive coating must not have obvious concave and convex		√	Visual Magnifier
	SI/UV glue not coated/ dropped or not fit in size		√	
	No glue in non-coating areas		√	
	Print position / font / text not in accordance with requirements		√	
	Easy to tear film color / position not in accordance with requirements		√	
	Incoming, process, ROHS process control, check for conformity	√		Visual
	Packaging and marking of the product are clear and correspond to the report	√		

The relevant information provided to the customer is complete When the customer has a request	√		
--	---	--	--

11.2.7 structure, packaging inspection:

Inspection items	Inspection criterion	Defect level		Inspection Methods and Tools
		MAJ	MIN	
Structure segment	The structure does not conform to the drawing size	√		Visual
Packing	Packaging material compliance	√		
	Packing Type Compliance	√		
	Tray or not	√		
	Packing Quantity Compliance	√		
	Product packaging (placement) direction meets the requirements	√		
	Cartons damaged/deformed		√	
	Labels are required on inner/external packing cases (content: model, date, etc)	√		

Remarks:

1. above all structural dimensions per batch sampling quantity of 10 PCS, bad is not qualified.
2. environmental protection requirements: product inspection
 - 2.1 Incoming, process, ROHS process control, check for conformity;
 - 2.2 Packaging and marking of the product are clear and correspond to the report
 - 2.3 The relevant information provided to the customer is complete When the customer has a request

12. Mechanical Drawing

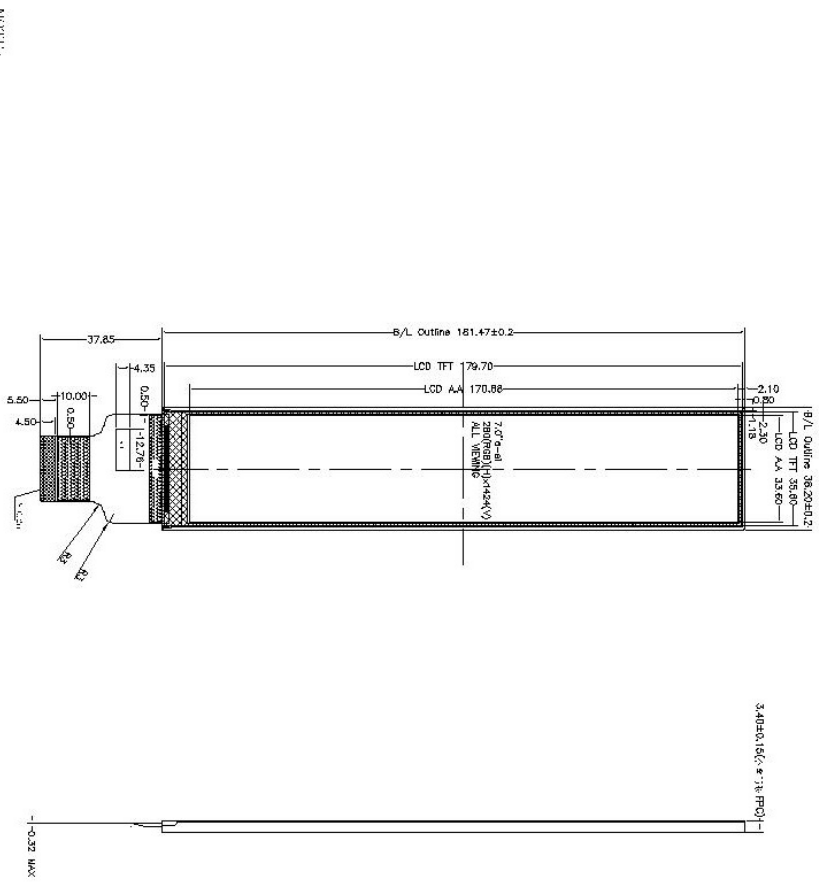

NOTE:
 Display type: T 0° a-si TFT
 Display mode: Transmissive Normally Black
 Interface Type: MIPI
 Driver IC: OIA7290B
 Input voltage: 3.0±0.2V
 Backlight: White LED (S-LED)
 Vled-21-27V Iled-20mA (max.)
 Operating temperature: 20° C ~ 70° C
 Storage temperature: 30° C ~ 80° C
 Interface connector: FPC

背光电路原理图:
 8*3=24POS
 驱动电流: 20mA (MAX)
 驱动电压: 21V-27V

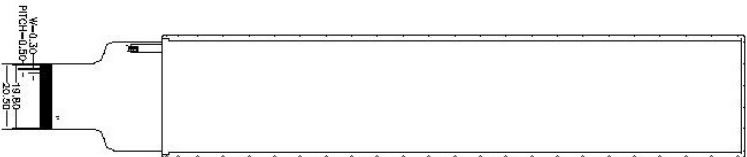

Pin	Explanation
1	VCOM
2	VDD
3	VDD
4	NC
5	RESET
6	STBYB
7	GND
8	D0-
9	D0+
10	GND
11	D1-
12	D1+
13	GND
14	D2-
15	D2+
16	GND
17	C1E-
18	C1E+
19	GND
20	D3-
21	D3+
22	GND
23	NC
24	NC
25	GND
26	NC
27	NC
28	NC
29	AVDD
30	GND
31	LEDB
32	LEDB
33	L-R
34	L-D
35	YGR
36	NC
37	NC
38	VGH
39	LEDA
40	LEDA

ROHS COMPLIANT	YES
UNMARKED TOLERANCE	±0.2
SCALE	FIT
SHEET 11 OF 11	REV. V00

TITLE	LCM
PART NO.	
MODULE NO.	CNKTD700-21375A1
CUSTOMER NO.	V00
DRAWN	
CHECKED	
APPROVED	
NAME	
DATE	2021-12-13

REV. SYMBOL	DESCRIPTION	NAME	DATE
V00	FIRST ISSUE		
MARK**ARE IMPORTANT DIMENSIONS**ARE REFERENCE DIMENSIONS**ARE SPECIAL CHARACTERISTICS RELATED TO SAFETY**ARE SPECIAL CHARACTERISTICS PRECEDANT TO SAFETY**ARE IMPORTANT CHARACTERISTICS EXCEPT FOR THE SPECIAL CHARACTERISTICS.			